

## Soldering tip Ø 1.5 mm, C245176E

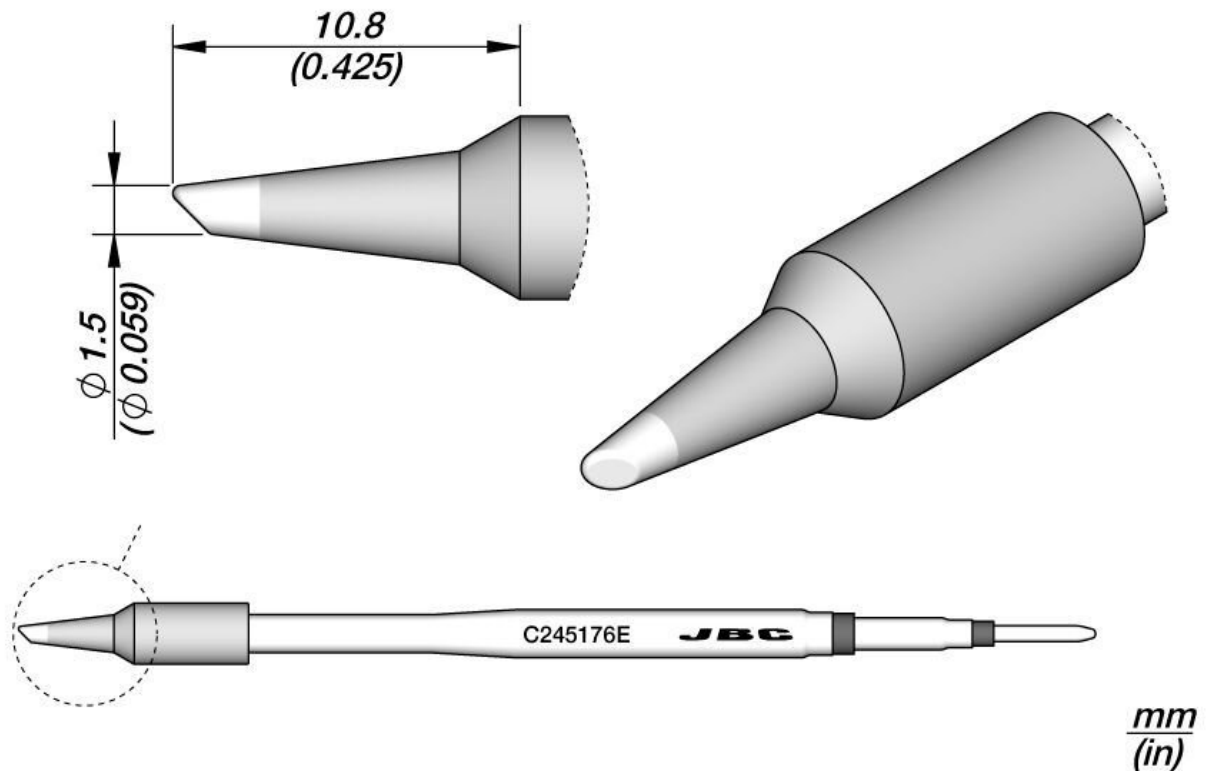

The C245E tips have been developed with a thicker iron layer, making this tip ideal for demanding and repetitive work in mass production. A thicker iron layer reduces thermal efficiency.

They are suitable for general soldering work and are perfect for both SMD components and high power applications such as ground plane soldering.

They are compatible with T245 handles.

Thanks to the JBC Most Efficient Soldering System and sleep and rest modes, they last five times longer than other brands.

Item no.	WL92355
Manufacturer	JBC
Manufacturer article no.	C245176E
GPSR manufacturer data	JBC Soldering SL Ramón y Cajal 3 ES-08750 Molins De Rei

Products for the electronic industry



	<a href="http://www.jbctools.com">www.jbctools.com</a>
Sales unit	1 piece
Content unit	1 piece
Product series	C245E
Tip series	C245E
Tip length	10.8 mm
Soldering tip diameter	1.5 mm
Tip alignment	sloped
Matching accessories	T245, T245P, T245N
ESD compliant	no