

## Soldering tip ERSADUR, 2.0mm/0.079in, 10 pcs

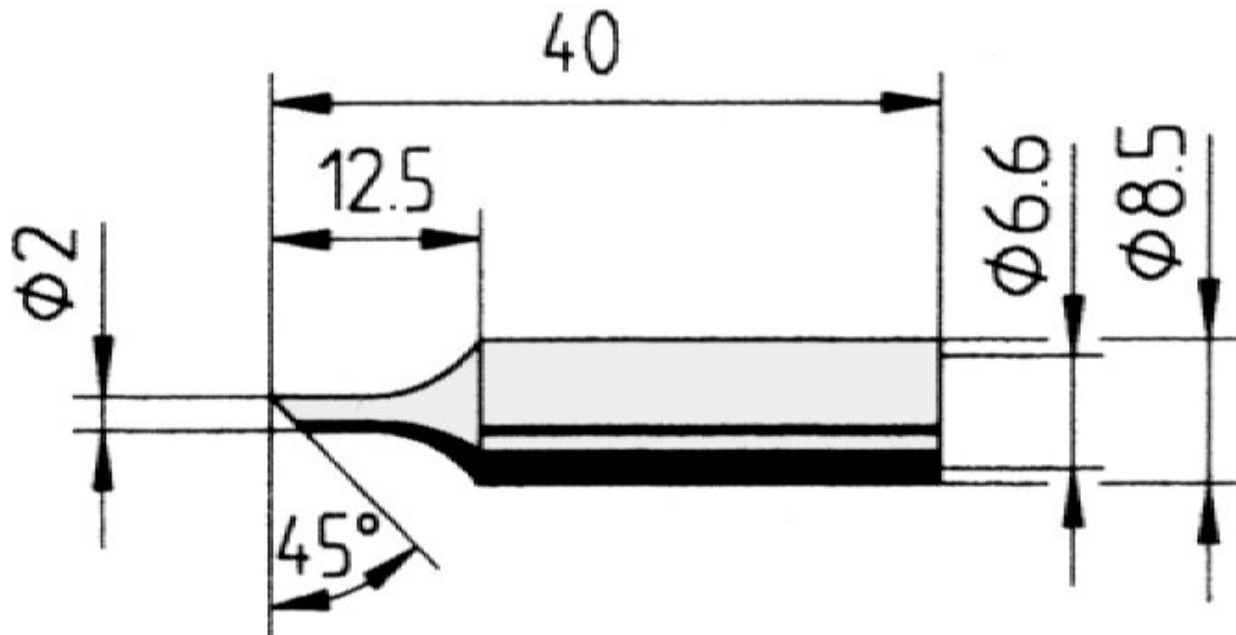

The straight, beveled soldering tip 2.0 mm from ERSA is ideal for precise soldering with lead-free solder paste.

With a 45° angle, 40 mm tip length and ERSADUR-LF coating, it offers increased service life and even solder deposition. The shaft diameter of 6.6 mm inside and 8.5 mm outside ensures a secure hold in the handpiece.

The soldering tips are compatible with numerous handpieces such as Power-Tool, Ergo-Tool, Multi-Pro, Multi-TC, Multi-Sprint and PTC 70 as well as the soldering stations ANALOG 60, DIGITAL 80, DIGITAL 2000 A and others. The packaging unit contains 10 pieces - ideal for the workshop, laboratory or series production.

- Continuous soldering tip, straight, bevelled 45° angle, 2.0 mm diameter, with ERSADUR-LF coating (lead-free soldering) for increased service life.
- suitable for the soldering stations ANANLOG60, ANALOG60A, DIGITAL80, DIGITAL80A, DIGITAL2000A, RDS80, MICRO-CON60, TWIN80A, ELS8000/M/D, MS6000 as well as MS8000

Item no. WL51121

Manufacturer ERSA

Products for the electronic industry



Manufacturer article no.	0832FDLF/10
GPSR manufacturer data	ERSA GmbH Leonhard-Karl-Strasse 24 DE-97877 Wertheim www.ersa.de
Length with packaging	70 mm
Width with packaging	55 mm
Height with packaging	20 mm
Sales unit	1 PU
Content unit	10 piece
Incl. battery	no
Product series	832
RoHS compliant	yes
Tip series	832
Inner diameter (shaft)	6.6 mm
Outer diameter (shaft)	8.5 mm
Tip length	40 mm
Soldering tip diameter	2 mm
Tip shape	tapered
Tip alignment	straight
Matching handpiece	ERGO TOOL, MULTI-PRO, MULTI-SPRINT, MULTI-TC, POWER-TOOL, PTC 70
ESD compliant	no