

Soldering tip R245, pin connector, Ø 2.5 mm, R245011

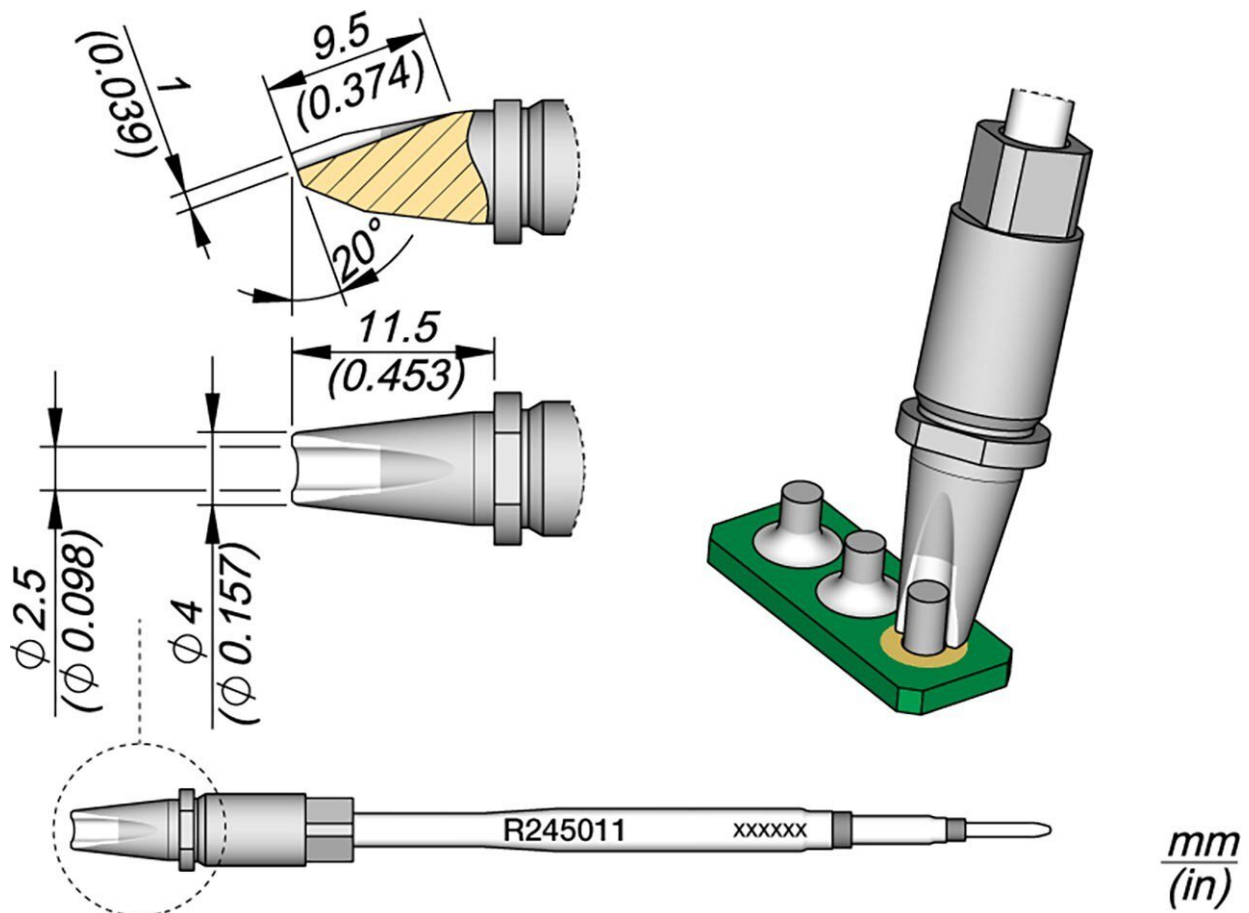

- for automated processes
- for standard soldering applications
- Design includes a square cross section that perfectly centers the soldering tip into the soldering iron and ensures precise vertical positioning
- due to this square cross-section the soldering tip can be inserted in 4 different positions, which can be changed in 90° steps

Item no.	WL50752
Model	R245-011
Manufacturer	JBC
Manufacturer article no.	R245011
GPSR manufacturer data	JBC Soldering SL Ramón y Cajal 3

Products for the electronic industry



ES-08750 Molins De Rei
www.jbctools.com

Sales unit	1 piece
Content unit	1 piece
Incl. battery	no
Product series	R245
Matching stand	CS2R245
Soldering tip or desoldering tip	soldering tip
Tip series	R245
Angle (soldering tip)	20 °
Outer diameter	4 mm
Tip dimensions	Ø 2,5 x 1 mm
Tip length	11.5 mm
Tip thickness	1 mm
Soldering tip diameter	2.5 mm
Tip applications	General use
Tip shape	round
Tip alignment	straight
Suitable soldering iron	TR245, TRA245
Matching handpiece	TR245, TRA245
Matching handpiece	TR245, TRA245
ESD compliant	no