

soldering tip R470, Pin Connector Ø 2 mm

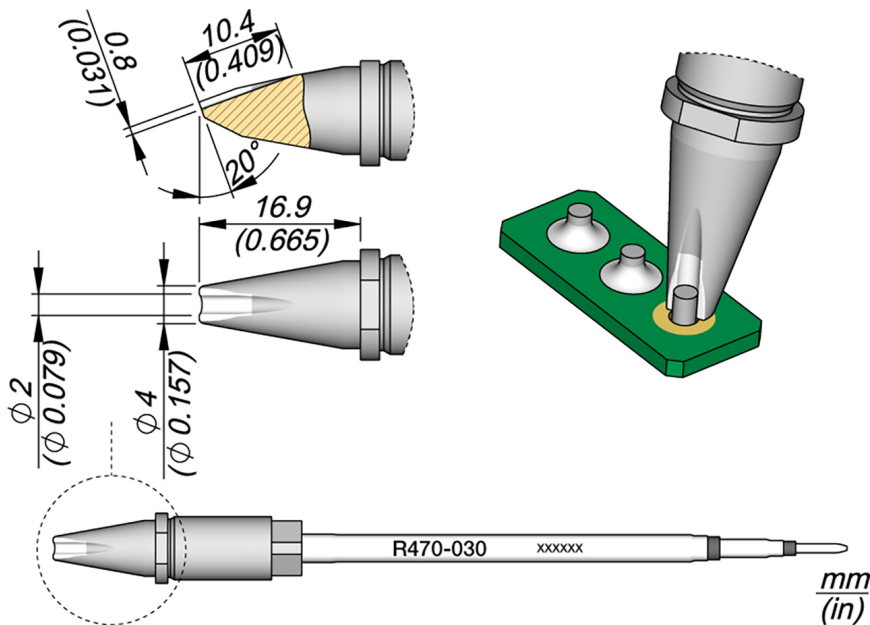

Description

- for heat intensive applications
- square cross-section, which perfectly centres the soldering tip in the soldering iron and ensures precise vertical positioning
- the soldering tip can be inserted in 4 different positions, which can be changed in 90° steps

Product details

item number	WL50748
manufacturer	JBC
manufacturer item number	R470030
order unit	piece
product series	R470
Tip series	R470
tip dimensions	Ø 2 mm
tip length	16.9 mm

Products for the electronic industry



tip alignment

straight

suitable handle

TR470, TRA470

