

Soldering tip R470, chisel, 2x1 mm

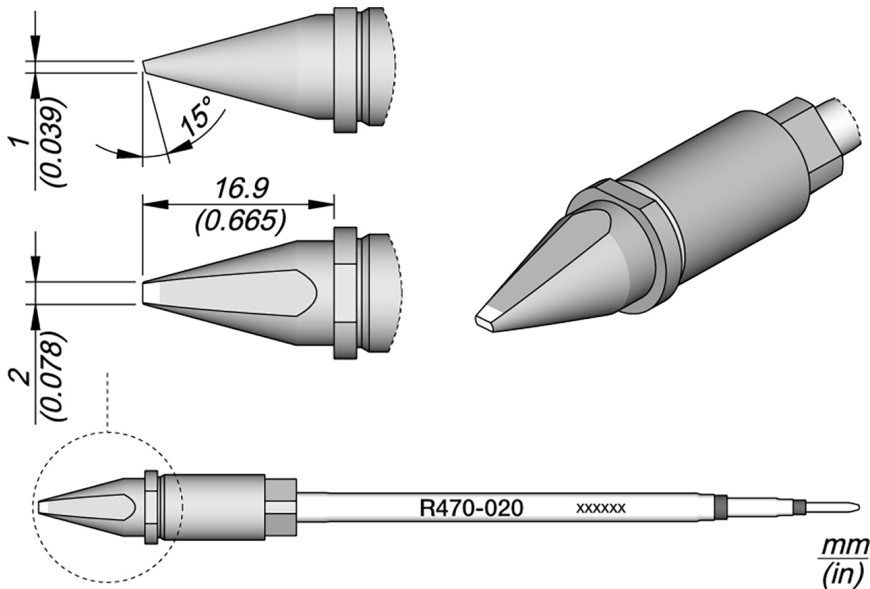

Description

- for heat intensive applications
- square cross-section, which perfectly centres the soldering tip in the soldering iron and ensures precise vertical positioning
- the soldering tip can be inserted in 4 different positions, which can be changed in 90° steps

Product details

item number	WL50745
manufacturer	JBC
manufacturer item number	R470020
order unit	piece
product series	R470
Tip series	R470
tip dimensions	2x1 mm
tip length	16.9 mm
tip shape	chisel-shaped

Products for the electronic industry



tip alignment

straight

suitable handle

TR470, TRA470

