

Soldering tip R470, chisel, 3 x 1.5 mm, R470016

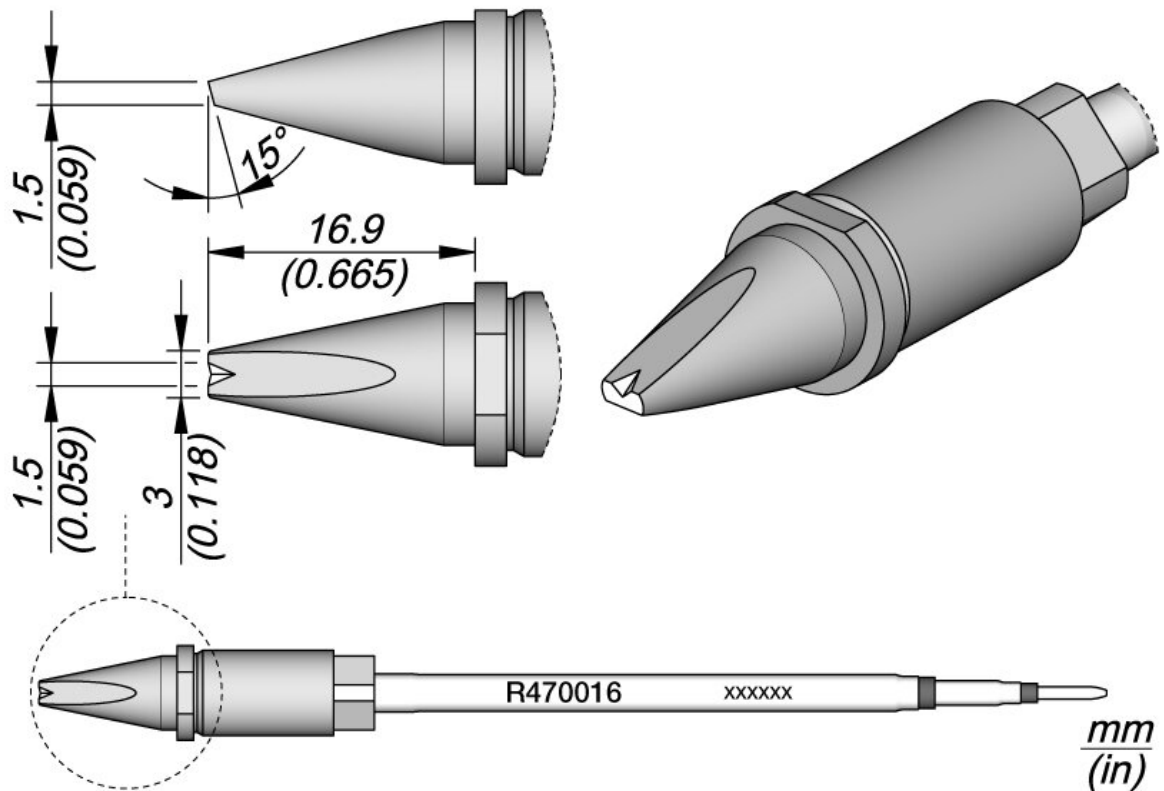

- Special tips for use in automated soldering processes
- new design includes a square cross section that perfectly centers the cartridge in the soldering iron and guarantees precise vertical positioning
- Due to the square cross section, the tip can be used in 4 different positions, which can be changed in 90° steps

item number	WL47999
model	R470-016
manufacturer	JBC
manufacturer item number	R470016
length with packaging	183 mm
width with packaging	60 mm
height with packaging	34 mm

order unit	1 piece
content unit	1 piece
product series	R470
suitable stand	CS2R470
soldering tip or desoldering tip	soldering tip
Tip series	R470
Soldering tip angle	15 °
tip dimensions	3 x 1,5 mm
tip length	16.9 mm
tip width	3 mm
tip thickness	1.5 mm
tip application	General use
tip shape	chisel-shaped
tip alignment	straight
suitable soldering iron	TR470, TRA470
suitable handpiece	TR470, TRA470
suitable handle	TR470, TRA470
ESD safe	no