

## Soldering tip R470, chisel, 4x1.5 mm

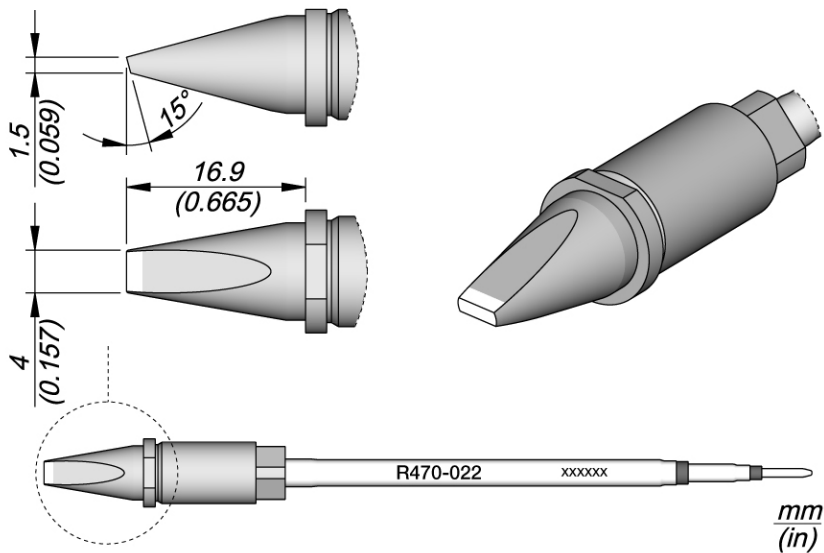

### Description

- for automated soldering processes
- square cross-section, which perfectly centres the soldering tip in the soldering iron and ensures precise vertical positioning
- the soldering tip can be inserted in 4 different positions, which can be changed in 90° steps

### Product details

item number	WL47680
manufacturer	JBC
manufacturer item number	R470022
model	R470-022
dimensions with packaging (LxWxH)	183 mm x 60 mm x 34 mm
order unit	piece
product series	R470
Tip series	R470
tip dimensions	4 x 1,5 mm

tip length	16.9 mm
tip shape	chisel-shaped
tip alignment	straight
suitable handle	TR470, TRA470

