

Soldering tip, straight, pencil tip, 0.4 mm, 0832UD

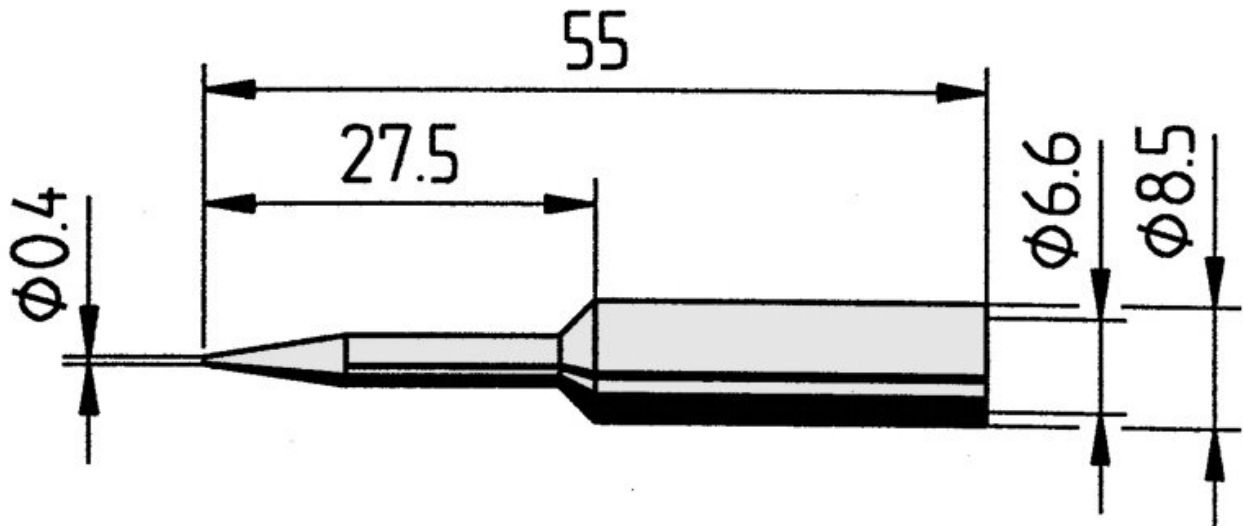

- Continuous soldering tip, straight, pencil tip, 0.4 mm diameter, with ERSADUR coating.
- suitable for soldering stations ANANLOG60, ANALOG60A, DIGITAL80, DIGITAL80A, DIGITAL2000A, RDS80, MICRO-CON60, TWIN80A, ELS8000/M/D, MS6000 as well as MS8000

Item no.	WL36115
Model	832UD
Manufacturer	ERSA
Manufacturer article no.	0832UD/SB
GPSR manufacturer data	ERSA GmbH Leonhard-Karl-Strasse 24 DE-97877 Wertheim www.ersa.de
Length	55 mm
Length with packaging	90 mm
Width with packaging	60 mm
Height with packaging	10 mm
Sales unit	1 piece
Content unit	1 piece
Total length	55 mm

Products for the electronic industry



Incl. battery	no
Product series	832
RoHS compliant	yes
Tip series	832
Inner diameter (shaft)	6.6 mm
Outer diameter (shaft)	8.5 mm
Soldering tip diameter	0.4 mm
Tip shape	pencil pointed
Tip alignment	straight
Coating of the soldering tip	permanent soldering tip
Matching handpiece	BASIC TOOL, ERGO TOOL, MULTI-PRO, MULTI-SPRINT, MULTI-TC, POWER-TOOL, PTC 70
ESD compliant	no