

## Soldering tip SxP series, chisel-shaped 30° 1.5 x 12.04 mm

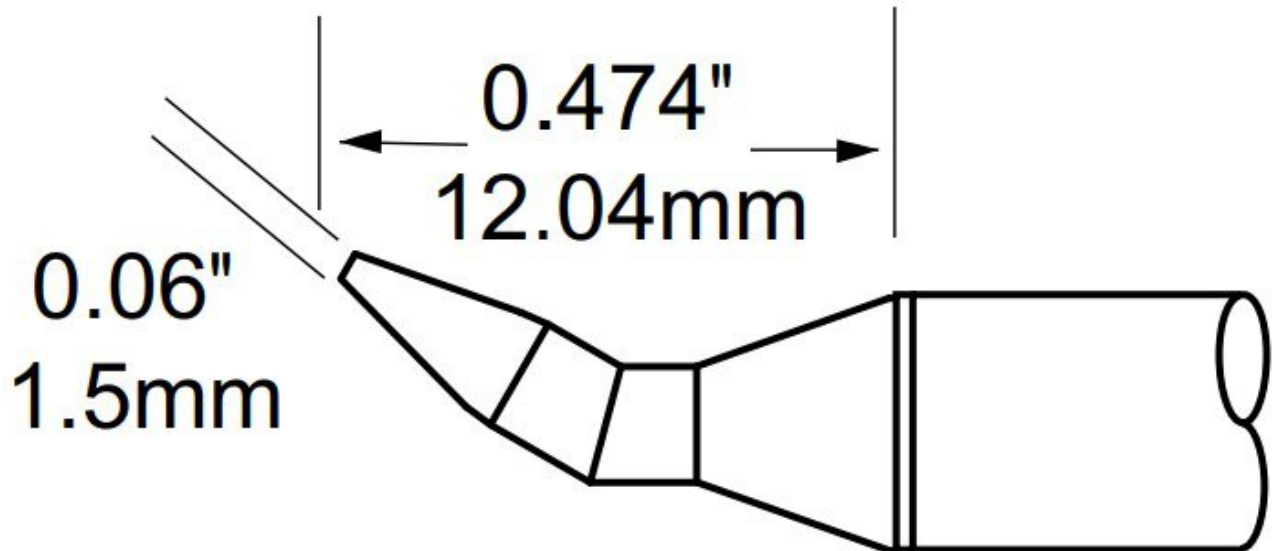

SxP-Solder Tip Cartridges are the standard soldering tip range for the Metcal MFR-1110, MFR-2210 and MFR-1351-series soldering systems. The second letter in the part number designates the temperature series. The Temperature series SFP are nominally 390 °C. Metcal recommends the SFP-series for the majority of applications. However, the family also offer a higher temperature serie designated SCP, nominally 450 °C, for high temperature and thermally demanding applications. STP-series are nominally 330 °C for light load application. Can be used with leaded and lead-free solder. The Metcal "SmartHeat®-Technology" automatically adjusts power levels during each soldering operation.

- suitable for ceramics and applications with high thermal requirements

Item no.	WL27521
Model	SCP-CHB15
Manufacturer	OKI
Manufacturer article no.	SCP-CHB15
GPSR manufacturer data	OK International Ltd Eagle Close, Chandlers Ford GB-SO53 4NF Hampshire www.ok-international.com
Sales unit	1 piece
Content unit	1 piece

Incl. battery	no
Product series	SxP Series
Temperature (max.)	471 °C
Tip series	SxP
Angle (soldering tip)	30 °
Tip length	12.04 mm
Tip width	1.5 mm
Tip shape	chisel-shaped
Tip alignment	bent
Tip temperature	460 °C
Matching handpiece	MFR-H1-SC
ESD compliant	no

## Other versions

Item no.	Temperature (max.)
WL24726	421 °C
<b>WL27521</b>	<b>471 °C</b>