

## Soldering tip SxV series, conical long 2 x 15 mm

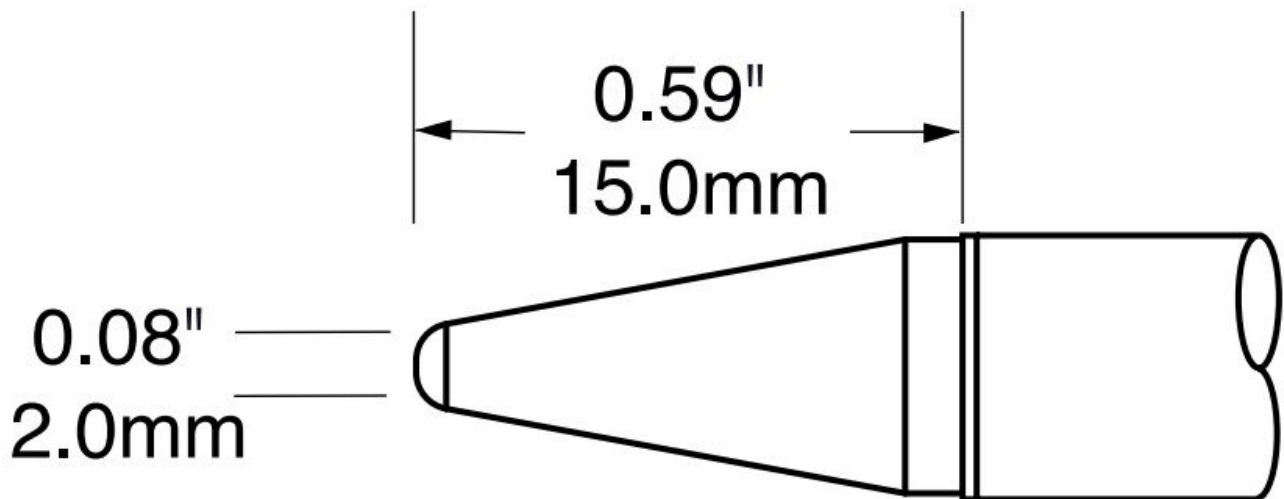

SxV-Solder Tips are the standard soldering tip range for the Metcal PS-900/MFR1100, MFR-2210, MFR-1351-series soldering systems. The second letter in the part number designates the temperature series. The temperature series SFV are nominally 390 °C. Metcal recommends the SFV-series for the majority of applications. However, the family also offer a higher temperature serie designated SCV, nominally 450 °C, for high temperature and thermally demanding applications. STV-series are nominally 330 °C for light load application. Can be used with leaded and lead-free solder The Metcal "SmartHeat®-Technology" automatically adjusts power levels during each soldering operation.

- for most standard applications
- suitable for the handpieces of PS and MFR systems

Item no.	<b>WL24790</b>
Model	SFV-CNL20
Manufacturer	OKI
Manufacturer article no.	SFV-CNL20
GPSR manufacturer data	OK International Ltd Eagle Close, Chandlers Ford GB-SO53 4NF Hampshire www.ok-international.com
Sales unit	1 piece
Content unit	1 piece
Incl. battery	no

Products for the electronic industry



Product series	SxV Series
Temperature (max.)	421 °C
Tip series	SxV
Tip length	15 mm
Tip width	2 mm
Soldering tip diameter	2 mm
Tip shape	conical
Tip alignment	straight
Tip temperature	421 °C
ESD compliant	no

## Other versions

Item no.	Temperature (max.)
WL24790	421 °C
WL27852	471 °C